

WE POWER YOUR DREAMS WITH INNOVATION

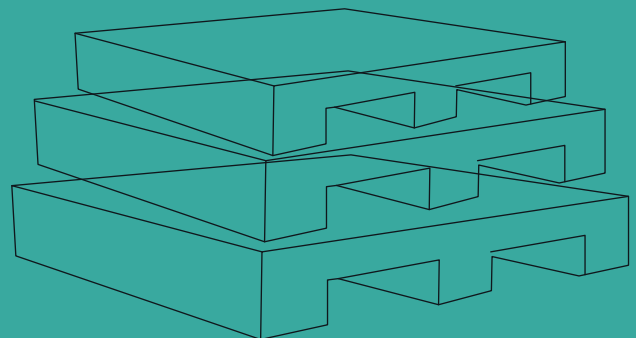

INSULATED TUBS | ICE BOX | PALLETS
SPILL PALLETS | DOFF BASKET | MILK CAN
SAFBIN | CHILLING PAD | PALLET CONTAINER
PROCESSING TROLLEY

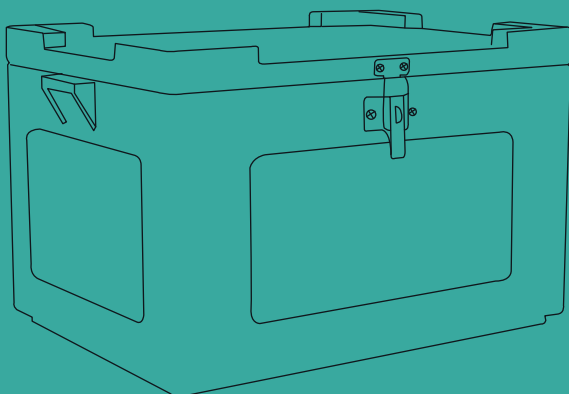
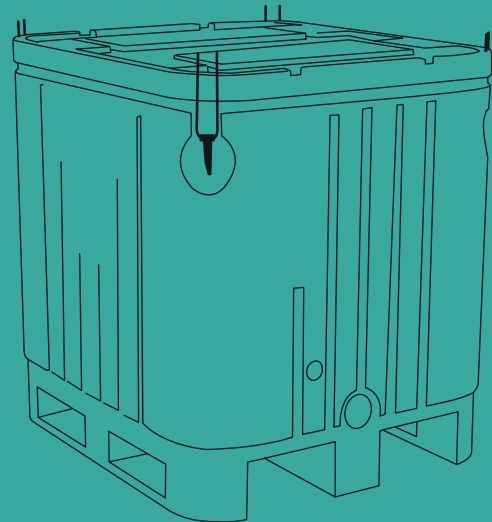
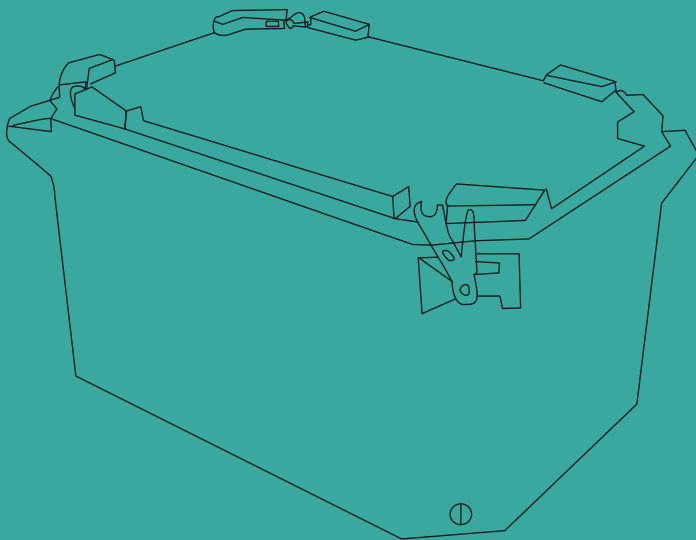

ABOUT US

Our Journey from Humble Beginnings to Pioneers of Rotational Moulding Excellence

Established in 1998, our rotational moulding company started with a vision and a small team of passionate individuals determined to make a difference. Over the years, we have grown and evolved into a leading force in the industry, transforming the way products are designed, manufactured, and distributed.

From the very beginning, we recognized the potential of rotational moulding as a versatile and innovative manufacturing process. With unwavering dedication and a commitment to excellence, we turned our humble beginnings into a success story that continues to unfold.

In our relentless pursuit of innovation has been defined by a series of milestones, achievements, and challenges that have moulded us into the company we are today.

Throughout the years, we have invested heavily in state-of-the-art machinery and embraced the latest advancements in the rotational moulding industry. This has allowed us to offer an extensive range of products that meet diverse needs across various sectors, from industrial applications to consumer goods and everything in between.

While technology has been crucial to our growth, it's our people who truly set us apart. Our team of skilled engineers, designers, and technicians brings a wealth of expertise and a passion for creativity to every project. Their dedication to pushing the boundaries of what's possible has resulted in groundbreaking solutions that consistently exceed our customers' expectations.

At the heart of our success lies our unwavering dedication to customer satisfaction. We view every client as a partner and take the time to understand their unique requirements. This personalized approach enables us to deliver tailor-made solutions that precisely match their needs and foster long-lasting relationships built on trust and reliability.

Today, as we reflect on our journey, we take pride in the mark we have made on the rotational moulding industry. From our small beginnings, we have grown into a company that sets the standard for innovation, quality, and environmental responsibility. As we move forward, we remain committed to shaping a brighter future through our revolutionary products and our unwavering dedication to excellence.

Join us on our journey as we continue to innovate, inspire, and lead the way in the world of rotational moulding. We look forward to embarking on new challenges and collaborating with you to bring your ideas to life. Together, let's create a world where possibilities are limitless, and innovation knows no bounds.

Our Vision

"To lead the future of rotational moulding through relentless innovation, sustainable practices, and unparalleled customer satisfaction."

Our Mission

"At our innovative rotational moulding company, we are committed to revolutionizing the industry by pushing the boundaries of what's possible. Through cutting-edge technology, eco-conscious practices, and a dedicated team, we strive to deliver high-quality, customized solutions that exceed our customers' expectations. Our mission is to create a greener world, one innovative product at a time, while fostering long-lasting partnerships with our clients and promoting a culture of excellence and sustainability within our organization."



DIRECTOR'S MESSAGE

In the current globalization, we in Allwin understand that meeting our customer's requirement is essential to the success of our organization. We can say that the years we experienced in the past are significant years and it is clearly seen that we have intensively delivered our best performance to focus on customer satisfaction. On behalf of Team Allwin, I would like to thank our valuable customers, reliable channel partners. Besides, I would like to make a special mention of our team's enthusiastic contribution in establishing our organization. The one thing I would like to present is that our leadership is a result of our Team. They have clearly made Allwin one of the outstanding organizations. We know our highly trained engineers apply their specialized knowledge to reliably and efficiently produce high quality products of world standards. We are now in an ever-innovative emerging modern organisation. We firmly believe that "trust" is the key element in persuading customers to choose our quality products. We totally accept that "trust" can create a "Win-Win Situation" for a long deeper relationship.



Our products with latest technologies and excellent service are diverse. It is easy to find them in every part of the world. We will continue our endless effort to serve our valuable customers.

I would like to thank again all those who have contributed in our growth in the past and to continue to grow for years to come.



OUR CORE TEAM

We have a dynamic team consisting of both seasoned professionals and enthusiastic, ambitious individuals who are committed to lifelong learning. This combination of experience and fresh perspectives enables us to thrive on innovation, driving our progress and growth.

As our team continues to expand and diversify, it is our shared values that unite us and guide our actions.



DIVE INTO QUALITY AND SUSTAINABILITY WITH OUR FISH BOXES AND AN OCEAN OF INNOVATIVE PRODUCTS!

Our insulated fish tubs are designed using the state of the art materials that provide superior thermal resistance. They maintain a stable internal temperature ensuring your perishable remain fresh and intact for an extended period.



ARP 335DX

Capacity (Ltrs.)	1000L
External Dimention (LxWxH in mm.)	1245x1115x1250
Internal Dimention (LxWxH in mm.)	1105x970x970



ARP 327DX

Capacity (Ltrs.)	700L
External Dimention (LxWxH in mm.)	1245x1115x930
Internal Dimention (LxWxH in mm.)	1110x980x685

ARP 50S

Capacity (Ltrs.)	50L
External Dimention (LxWxH in mm.)	580x410x500
Internal Dimention (LxWxH in mm.)	685x425x285



ARP 70S

Capacity (Ltrs.)	70L
External Dimention (LxWxH in mm.)	750x490x390
Internal Dimention (LxWxH in mm.)	685x425x285

ARP 100S

Capacity (Ltrs.)	100L
External Dimention (LxWxH in mm.)	815x535x440
Internal Dimention (LxWxH in mm.)	740x470x335



SUPERIOR INSULATION BOXES





ARP 220S

Capacity (Ltrs.)	220L
External Dimention (LxWxH in mm.)	970x585x655
Internal Dimention (LxWxH in mm.)	900x520x515

ARP 260S

Capacity (Ltrs.)	260L
External Dimention (LxWxH in mm.)	915x720x800
Internal Dimention (LxWxH in mm.)	820x625x560



ARP 310S

Capacity (Ltrs.)	310L
External Dimention (LxWxH in mm.)	915x710x780
Internal Dimention (LxWxH in mm.)	865x660x590



ARP 460S

Capacity (Ltrs.)	460L
External Dimention (LxWxH in mm.)	1230x1025x660
Internal Dimention (LxWxH in mm.)	1166x961x430



PORTABLE FREEZING POWER

Despite their exceptional insulation capabilities our boxes are light weight and sturdy. The Design allows for easy handling, reducing shipping costs and ensures long lasting performances.





ARP 500 R

Capacity (Ltrs.)	415L
External Dimention (DxH in mm.)	1150x660
Internal Dimention (DxH in mm.)	1080x505

ARP 660S

Capacity (Ltrs.)	660L
External Dimention (LxWxH in mm.)	1230x1025x825
Internal Dimention (LxWxH in mm.)	1166x961x600



ARP 1000S

Capacity (Ltrs.)	1000L
External Dimention (LxWxH in mm.)	1470x1160x960
Internal Dimention (LxWxH in mm.)	1390x1100x710

ARP 1250S

Capacity (Ltrs.)	1250L
External Dimention (LxWxH in mm.)	1830x915x915
Internal Dimention (LxWxH in mm.)	1760x840x845



KEEP THE QUALITY INTACT WITH PROVEN INSULATION

Our boxes are versatile. They cater to a wide range, of industries including food beverages, pharmaceuticals, floral or more. Whenever you need to store, transport perishables goods or maintain product integrity during storage Allwin boxes is the sure answer.





ARP 22-1

Capacity (Ltrs.)	22L
External Dimension (LxWxH in mm.)	470x380x225
Internal Dimension (LxWxH in mm.)	430x332x160



ARP 35-1*

Capacity (Ltrs.)	35L
External Dimension (LxWxH in mm.)	390x320x435
Internal Dimension (LxWxH in mm.)	345x275x370



ARP 20-1

Capacity (Ltrs.)	20L
External Dimension (LxWxH in mm.)	365x300x335
Internal Dimension (LxWxH in mm.)	695x320x320



ARP 25-1*

Capacity (Ltrs.)	25L
External Dimension (LxWxH in mm.)	390x320x335
Internal Dimension (LxWxH in mm.)	345x275x280



ARP 35-C

Capacity (Ltrs.)	35L
External Dimension (LxWxH in mm.)	600x420x260
Internal Dimension (LxWxH in mm.)	550x370x180

*Model available with plain & vending lid

PERFECT CHILL COMPANION FOR DAIRY

Our boxes are designed with user friendliness in mind. They come with convenient features like secure closures, ergonomic handles to material handling and transportation a breeze.





ARP 35-M*

Capacity (Ltrs.)	35L
External Dimention (LxWxH in mm.)	522x332x360
Internal Dimention (LxWxH in mm.)	472x282x270

ARP ARP-R

Capacity (Ltrs.)	5L
External Dimention (LxWxH in mm.)	DIA 267 x H 192
Internal Dimention (LxWxH in mm.)	DIA 204 x H 145

*Model available with plaing & Vending Lid



ARP 40-IB

Capacity (Ltrs.)	40L
External Dimention (LxWxH in mm.)	350x350x680
Internal Dimention (LxWxH in mm.)	280x280x610

ARP 50-IB*

Capacity (Ltrs.)	50L
External Dimention (LxWxH in mm.)	560x405x400
Internal Dimention (LxWxH in mm.)	515x360x305



ARP 60-IB*

Capacity (Ltrs.)	60L
External Dimention (LxWxH in mm.)	575x425x425
Internal Dimention (LxWxH in mm.)	510x360x375

*Model available with plain & vending lid

PICNIC ESSENTIALS - FOR FRESHNESS ON THE GO

We are committed to hygiene. Our boxes are made from FDA approved grades to make it most ideal for food/beverages. You can trust that you are making a responsible choice.



ARP 60 COOLER BOX

Capacity (Ltrs.)	60L
External Dimention (LxWxH in mm.)	750x530x525
Internal Dimention (LxWxH in mm.)	660x435x390



ARP 80-IB

Capacity (Ltrs.)	80L
External Dimention (LxWxH in mm.)	640x330x700
Internal Dimention (LxWxH in mm.)	560x250x610



ARP 97-IBVL*

Capacity (Ltrs.)	97L
External Dimention (LxWxH in mm.)	660x508x710
Internal Dimention (LxWxH in mm.)	510x375x570

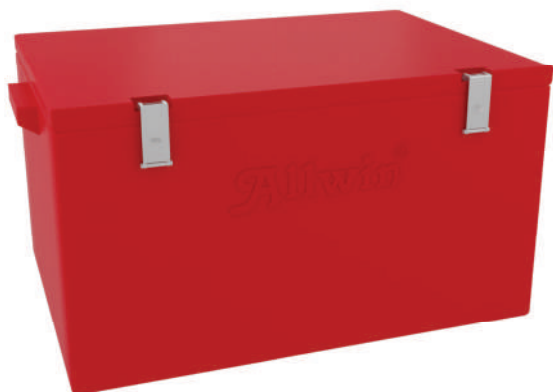

ARP 100-IB*

Capacity (Ltrs.)	100L
External Dimention (LxWxH in mm.)	780x555x455
Internal Dimention (LxWxH in mm.)	690x465x355



ARP 110-IBVL*

Capacity (Ltrs.)	110L
External Dimention (LxWxH in mm.)	750x530x525
Internal Dimention (LxWxH in mm.)	660x435x390

*Model available with plain & vending lid

FROZEN DELIGHTS, ANYWHERE, ANYTIME

Are you worried about perishables goods losing their freshness during storage / movements. Look no further we are proud to present our innovations – superior insulated boxes. – The ultimate solution for all your temperature sensitive needs.



ARP 120-IBVL*

Capacity (Ltrs.)	120L
External Dimension (LxWxH in mm.)	610x610x630
Internal Dimension (LxWxH in mm.)	510x510x485



ARP150-IBCT*

Capacity (Ltrs.)	150L
External Dimension (LxWxH in mm.)	815x590x735
Internal Dimension (LxWxH in mm.)	660x435x580



ARP 150-IB*

Capacity (Ltrs.)	150L
External Dimension (LxWxH in mm.)	830x585x590
Internal Dimension (LxWxH in mm.)	730x485x460



ARP 150-IBVLLL

Capacity (Ltrs.)	150L
External Dimension (LxWxH in mm.)	905x502x725
Internal Dimension (LxWxH in mm.)	750x370x580



ARP 250-IBVLL

Capacity (Ltrs.)	250L
External Dimension (LxWxH in mm.)	1040x600x765
Internal Dimension (LxWxH in mm.)	865x485x610

*Model available with plain & vending lid

REVOLUTIONIZE LOGISTICS WITH TECH-DRIVEN PALLETS

The introduction of the superior plastic pallet revolutionizes the traditional material handling landscape, offering a game-changing solution to various industries. This innovative pallet design combines cutting-edge materials and engineering expertise to provide unmatched performance and long-term value.

The superior Allwin plastic pallet represents a paradigm shift in pallet design and functionality. It's specifically engineered to enhance the efficiency and safety of material handling processes across manufacturing, warehousing, and distribution sectors. As industries continue to embrace innovation and adapt to changing demands, the superior plastic pallet stands as a symbol of progress, ensuring a safer, greener, and more streamlined future for global supply chain.

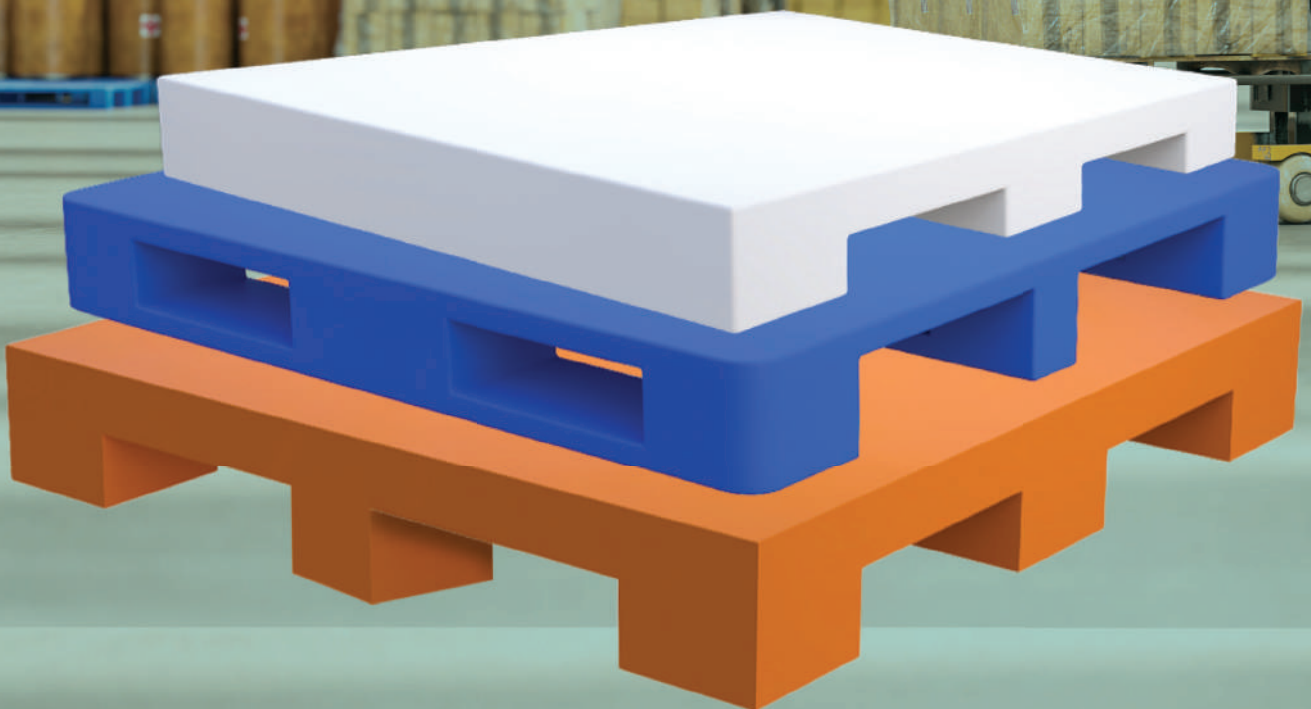

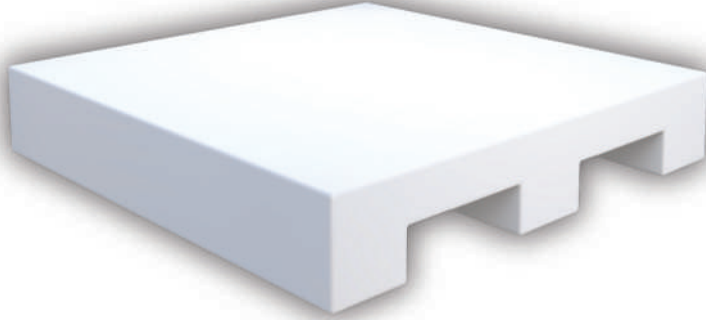

3 RUNNERS, 2 WAY ENTRY

Model	Size (MM)	Load Capacity
ARP1208R32	1200 L x 800 W x 160 H	Upto 1 to 5 Tons
ARP8080R32	800 L x 800 W x 160 H	Upto 1 to 5 Tons
ARP1212R32	1200 L x 1200 W x 160 H	Upto 1 to 5 Tons
ARP1210R32	1200 L x 1000 W x 160 H	Upto 1 to 5 Tons
ARP1010R32	1000 L x 1000 W x 150 H	Upto 1 to 5 Tons
ARP1008R32	1000 L x 800 W x 150 H	Upto 1 to 5 Tons

3 RUNNER, 4 WAY ENTRY

Model	Size	Load Capacity
ARP1512R34	1500 L x 1200 W x 160 H	Upto 1 to 5 Tons
ARP1212R34	1200 L x 1200 W x 160 H	Upto 1 to 5 Tons
ARP1210R34	1200 L x 1000 W x 160 H	Upto 1 to 5 Tons
ARP1208R34	1200 L x 800 W x 160 H	Upto 1 to 5 Tons



9 LEGS, 4 WAY ENTRY

Model	Size	Load Capacity
ARP1212L9	1200 L x 1200 W x 160 H	Upto 1 to 5 Tons
ARP1210L9	1200 L x 1000 W x 160 H	Upto 1 to 5 Tons
ARP1010L9	1000 L x 1000 W x 150 H	Upto 1 to 5 Tons

7 RUNNER, 2 WAY ENTRY

Model	Size	Load Capacity
ARP1608R32	1600 L x 800 W x 160 H	Upto 1 to 5 Tons



INNOVATIVE SOLUTIONS



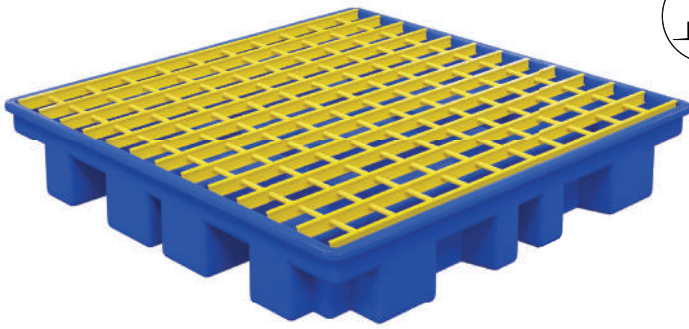

4 DRUM PALLET (SINGLE WALL)

Model	Size (MM)	Volume (Ltr.)
ARP 1313 SPILL	1300L x 1300W x 200H	150 Ltr.

Drain Facility Optional*PE & GRP Top Options

2 DRUM PALLET (SINGLE WALL)

Model	Size (MM)	Volume (Ltr.)
ARP 127820 SPILL*	1270L x 780W x 200H	130 Ltr.

Drain Facility Optional*PE & GRP Top Options

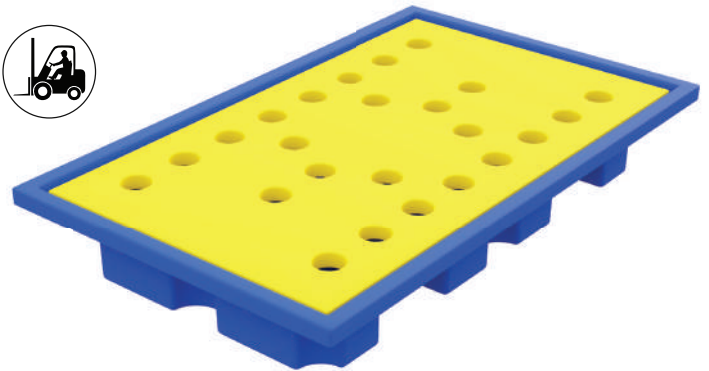

Drain Facility

4 DRUM PALLET (DOUBLE WALL)

Model	Size (MM)	Volume (Ltr.)
ARP SPILL 131350 DW*	1350L x 1350W x 500H	440 Ltr.

*PE & GRP Top Options



2 DRUM PALLET (DOUBLE WALL)

Model	Size (MM)	Volume (Ltr.)
ARP SPILL 137840 DW*	1350L x 780W x 400H	150 Ltr.

*PE & GRP Top Options

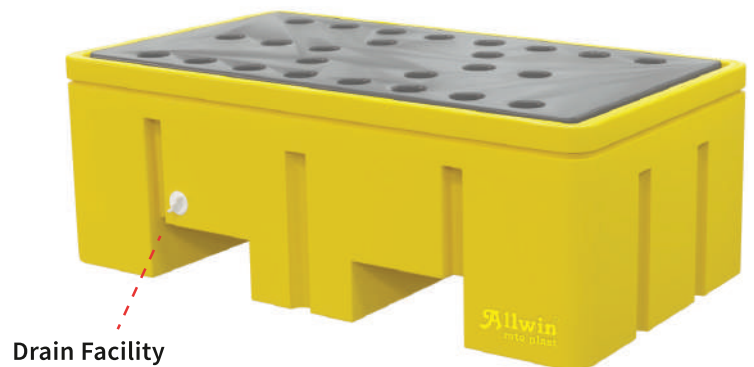

Drain Facility



**SAFE &
HYGIENIC**



ROLL PALLET

Model	Size (MM)	Load Capacity
ARP1210R34 ROLL	1200 L x 1000 W x 260 H	Upto 1 to 5 Tons

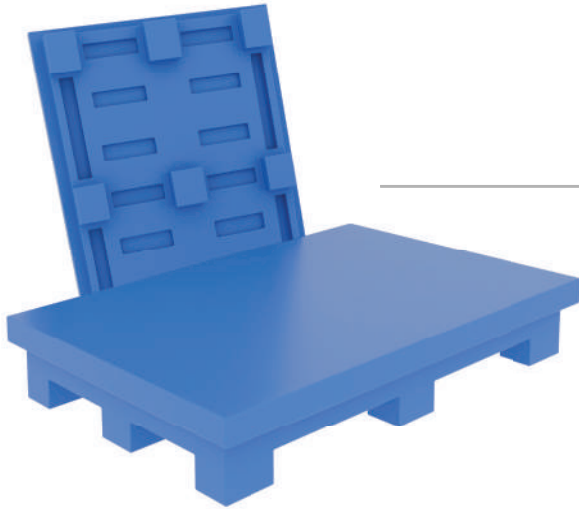
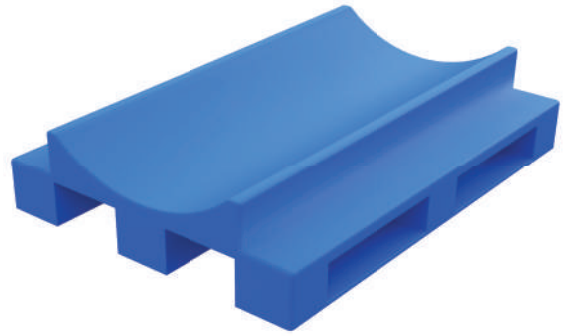

KISS OF PALLET

Model	Size (MM)	Load Capacity
ARP 1208 L9	1200 L x 800 W x 160 H	Upto 1 to 5 Tons

PALLET CONATINER

Model	Size (MM)	Load Capacity
ARP 1000 PLC	1180 L x 1010 W x 1040 H	Upto 1 to 5 Tons



SAFBINS



Model	Diameter		Height	Approx Capacity
	Top	Bottom		
ARP 40 CV	455	310	490	40
ARP 50 CV	445	410	465	50
ARP 60 CV	435	400	560	60
ARP 80 CV	470	410	715	80
ARP 100 CV	535	475	640	100
ARP 120 CV	565	505	640	120
ARP 200 CV	585	575	910	200

Disclaimer

*The basic raw materials for the pallets are added with stabilisers of recommended LDR and the results are tested in accredited laboratories in India for various anti-bacterial and other hygiene. properties.



JOIN THE CLEAN REVOLUTION WITH SUPERIOR WASTE BINS

Embrace the future of waste management with superior waste bins. Enjoy the benefits of smart technology and sustainable waste disposal. Together lets work towards a cleaner and greener tomorrow.





ARP 60 DB

Size	Capacity
300Lx300Wx680H	60 Ltrs.



ARP 80 DB

Size	Capacity
430Lx430Wx875H	80 Ltrs.



ARP 110 DB

Size	Capacity
515Lx515Wx920H	110 Ltrs.



ARP DB S

Size
525Lx360Wx1040H

ARP DB SS

Size
1090Lx360Wx1040H

ARP DB SSS

Size
1760Lx360Wx1040H

DURABILITY MEETS UNCOMPROMISING HYGIENE





ARP 240 & 120 DBW

Size	Capacity
750Lx570Wx1010H	240 Ltrs.
570Lx500Wx950H	120 Ltrs.

ARP 260 & 210 C

Size	Capacity
932Lx615Wx523H	260 Ltrs.
810Lx530Wx583H	210 Ltrs.
585Lx385Wx330H	70 Ltrs.
390Lx290Wx325H	30 Ltrs.



CHOOSE SUPERIOR MILK CANS FOR OPTIMAL MILK PRESERVATION

Invest in the finest milk cans that safeguard the quality and freshness of milk from the farm to dairy upgrade to superior milk cans today and experience the benefits of reliable transportation, easy handling and maintaining freshness of milk.





ARP IMC 40

Size	Capacity
205Tx380Bx700H	40 Ltrs.



📍 753/B, B/h. Cadila Corporate Campus, Sarkhej-Dholka Road, Vill.: Bhat,
Tal.: Daskroi, Dist.: Ahmedabad-382210, India.

☎ +91 84690 00194, +91 94261 77529

✉ sales@allwinrotoplast.com 🌐 www.allwinrotoplast.com

